

Composite dry sliding bushings, Composite dry sliding flanged bushings

Principal dimensions					Basic load ratings				Mass	Designation
d	D	D1	B	B1	radial dynamic C	static C0	axial dynamic Ca	static C0	kg	-
mm					kN					
25	28	35	16,5	1,5	28	85	20,4	64	0,021	PCMF 252816.5 E

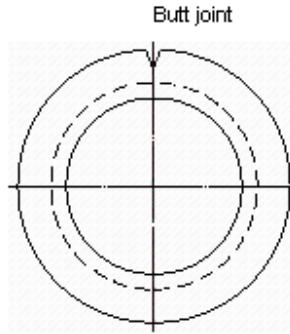
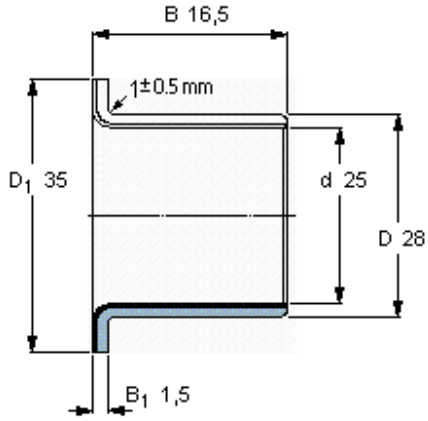

Specific load factor
Material constant

K 80
K_M 480